

Proposing A Web-Based Interactive Module for Education for Sustainable Development in English for Computer Science

Dewi Sari Wahyuni¹, Yenni Rozimela^{2*}, Havid Ardi³, Mukhaiyar⁴, T. Sy. Eiva Fatdha⁵

Post Graduate Program, Universitas Negeri Padang^{1,2}
Faculty of Language and Art, Universitas Negeri Padang^{3,4}
Program Study of Information Technology, STMIK Amik Riau⁵

*) Corresponding Author

Email: yenni.rozimela@fbs.unp.ac.id
DOI: 10.18326/rgt.v16i1.1-23

Submission Track:

Received: 10-09-2022

Final Revision: 25-04-2023

Available Online: 01-06-2023

Copyright © 2023 Authors



This work is licensed under a Creative Commons Attribution-ShareAlike 4.0 International License.

Abstract

English for Computer Science (ECS), as part of English for Specific Purposes (ESP), is designed to teach students the English required in computer science. In this paper, the writers proposed to incorporate Education for Sustainable Development (ESD) into ECS to encourage student engagement by presenting current concerns relevant to their life experiences. The work is a position paper in which the writers argue for the importance of building a web-based interactive module for ESD in ECS. Our arguments are supported in the following sections; English for Specific Purposes (ESP), Content Language Integrated Learning (CLIL), English for Computer Science (ECS), Education for Sustainable Development (ESD), Instructional Material limited to Module and E-Module, and related research. The writers propose developing an interactive web-based module for ESD in ECS so that students have more fun while they are studying. It is anticipated that students will be able to study the module at their own pace and according to their capabilities. This module is paperless; it contributes to the Sustainable Development Goals (SDGs). As instructional materials, the module will also assist ECS students in overcoming classroom time constraints and relating what they learn to future concerns, careers, and professionalism.

Keywords: web-based interactive module; education for sustainable development; english for computer science

INTRODUCTION

Besides courses offered in the English department, universities provide English classes as part of their general courses. One of them is English for Computer Science (ECS). The primary purpose of this course is to enable students to communicate effectively in English within computer science. ECS is a component of English for Specific Purposes (ESP) as well as Content and Language Integrated Learning (CLIL).

Theoretically, ESP class is designed for participants with intermediate or advanced General English (GE) skills, as the level of difficulty is deemed extreme for those with lower skills (Anthony, 1997; Dudley-Evans, 1997; Dudley-Evans et al., 1998; Belcher, 2009; Rahman, 2015). The majority of ECS students are at the beginning level (Wahyuni et al., 2021), and this low level of English proficiency has become typical in Indonesian universities, even though these students have studied English since elementary school (Lestariningsih et al., 2017). In the category of false beginners, these students require more than one semester to complete the prerequisites for entry into the ECS theory course (Dudley-Evans, 1997; Dudley-Evans et al., 1998). However, as determined by field observations, students do not need to be at the above-mentioned level of proficiency to enroll in this class. Therefore, learning media and instructional materials are required to bridge this gap.

Previous research has also revealed that ECS students lack ESP-compatible teaching resources and tend to study GE to fulfill their English requirements (Nisar, 2016; Mahmood, 2017; Septiana et al., 2020; Andas et al., 2021). On the other hand, there is a call for a curriculum that strikes a compromise between the needs of the workplace and professionalism (Kaneko et al., 2009; Irshad & Anwar, 2018; Andas et al., 2021).

Although consistency with ESP in choosing materials and teaching materials has been observed in several universities (Puspitasari, 2013; Amna & Christina, 2021; Wahyuni et al., 2021), the content of ECS learning does not yet accommodate ESD. It is irrelevant to what students need for a sustainable future and present. Moreover, computer science has a close connection with the SDGs' focus areas. In addition to the fact that information technology systems are utilized in every aspect

of sustainable development (Gordon, 2010; Suryawanshi & Narkhede, 2015; Lässig, 2016; Mateusz et al., 2018; How et al., 2020; Koniukhov & Osadcha, 2020; Nwankwo & Njoku, 2020; Hiran et al., 2021).

Numerous types of research have been undertaken on the adoption of ESD in institutions of higher education. Some of these ESDs, especially those related to the UNESCO ESD framework for 2030, are unique courses or courses on Sustainable Development, while others are incorporated in courses given as part of other majors or courses or integrated into multiple courses. ESD is a vital component of education for a sustainable future, regardless of how it is disseminated (Verhulst & Lambrechts, 2015; Howlett et al., 2016; Leal Filho et al., 2017; Lozano et al., 2017; Syakur & Sabat, 2020; Franco et al., 2019; Castellanos & Queiruga-Dios, 2021; Chaleta et al., 2021).

The writers remark that there have been numerous investigations of ESD in ELT (Zygmunt, 2016; Maley & Peachey, 2017; Mohammadnia & Moghadam, 2019; Sund & Gericke, 2020), particularly in GE. However, aside from environment-related courses, there are few ESP courses (Lavrysh & Lytovchenko, 2019). ESD has also been introduced into the curriculum of classes at the university level. One is a computer science course (Gordon, 2010; Hromkovič et al., 2016; Grosseck et al., 2019; Rashid, 2019; Nwankwo & Njoku, 2020; Koniukhov & Osadcha, 2020). Unfortunately, there is no evidence that ESD has been included in English learning for computer science or ECS, although computer science programs have begun to use ESD.

Moreover, Symonenko (2020) highlighted that lecturers must use ESD content to satisfy the needs of the professional community and ensure the proper degree of English proficiency. According to her, the ECS must have a flexible context and real-world variables, taking into account scientific disciplines, their current state, and approaches and ideas for accomplishing SDGs. It includes learning content, results, pedagogy, and the physical learning environment.

Therefore, the study materials for the ECS program that are limited to technical areas linked to computers are no longer applicable, as computer science itself is tied to the entire field of SDGs, and ESD is the spirit of attaining all of these SDGs. This has not been incorporated into the present textbooks and instructional modules (Irshad & Anwar, 2018; Septiana et al., 2020; Symonenko, 2020; Andas et al., 2021). The writers argue that ESD must be incorporated into ECS to address the

requirements and interests of students in their future sustainable lifestyle and to equip them to recognize expected future career paths.

Given this, it is necessary to provide instructional materials that allow students to learn comfortably in terms of their time and skills. The majority of ECS students are at the beginner level (Wahyuni et al., 2021), and low English proficiency has become widespread in Indonesian universities, even though these students have studied English since elementary school (Lestariningsih et al., 2017). This category of students is a false beginner, and it takes them longer than one semester to qualify for ECS class entry. In truth, the aforementioned proficiency level is not required to enroll in the ECS course.

The module is the most suitable instructional material for addressing the aforementioned issues. Modules with organized and presented learning content are anticipated to enable students to absorb information independently or with minimal assistance (Rahdiyanta, 2016; LKPP-Unhas, 2015). Moreover, digital learning is intrinsically linked to today's students, so it is essential to use technology to improve learning outcomes to achieve a higher level of learning. Adapting the learning process to the current development level through the use of web-based interactive modules is a viable alternative (Fatdha & Wahyuni, 2017; Triyono, 2021; Brateanu et al., 2019; Suppan et al., 2020; Prasetya, 2021).

The module that will be developed is an interactive web-based module that will make learning more engaging for students. The module also contributes directly to the SDGs because it is paperless and environmentally friendly. This interactive ESD in the ECS module is designed to help ECS students overcome their limited class time by allowing them to study outside of the classroom at their own pace and level of ability and to maintain their interest in learning. It is believed that digital technology and the internet can improve student learning abilities and have a positive impact on learning outcomes (Mulyadi et al., 2019; Adawiyah & Susilawati, 2020; Ramadhan & Linda, 2020; Rahmatsyah & Dwiningsih, 2021; Erna & Anwar, 2021).

Wahyuni et al. (2021) administered a GE test based on the Common European Framework (CEFR) standards to 65 Computer Science students. They discovered that 91% of students were at level A1 and 9% were at level A2, even though the ESP class was theoretically reserved for participants with a minimum of B1 according to CEFR standards. Since it is impossible to adjust ECS to students'

proficiency level, there must be media in the form of instructional materials that support student learning. In addition, the content of these instructional materials must incorporate ESD.

In light of the aforementioned, the writers propose to build a web-based interactive module for ESD in ECS to make learning more engaging (Fatdha & Wahyuni, 2017; Triyono, 2021; Brateanu et al., 2019; Suppan et al., 2020; Prasetya, 2021). The module will allow students to study according to their skills on their own time (Rahdiyanta, 2016). It is paperless; therefore, the module will contribute to the SDGs and assist ECS students in overcoming the restrictions of learning time in the classroom and relating what they learn to what they will need to prepare for future issues, jobs, and professionalism.

RESEARCH METHOD

This position paper presents the writers' arguments on the need for specific instructional materials for ECS. Literature studies were carried out on earlier research about Education for Sustainable Development (ESD), Sustainable Development Goals (SDGs), English for Specific Purposes (ESP), English for Computer Science (ECS), and English Language Teaching and Learning. Many different kinds of resources available, such as journals, conference proceedings, websites, electronic books, and any other relevant sources, are utilized.

The procedures for analyzing data in the literature study are as follows:

1. Grouping the resources based on the following topic and years published; 1) English for Specific Purposes, 2) English for Computer Science, 3) Content and Language Integrated Learning, 4) English for Computer Science, 5) Education for Sustainable Development, and 6) Instructional Materials.
2. Finding the relatedness of each resource for each topic and then relating them with different topics to support our argumentation.
3. Presenting the data by indirect quoting to support our arguments in the paper.

RESULTS AND DISCUSSION

English for Specific Purposes (ESP)

Specialists often divide English Language Teaching into two groups when defining it: General English (GE) and English for Specific Purposes (ESP). English for Specific Purposes is therefore divided into English for Academic Purposes

(EAP) and English for Specific Purposes (EOP) (EOP). Some argue that EAP is a component of ESP, whilst others argue that EAP is not a component of ESP by itself.

Historically, EAP was created for overseas students enrolling in institutions in English-speaking nations whose major Medium of Instruction was English (EMI). Standardized tests such as the TOEFL, IELTS, TOEIC, and Cambridge Exam are commonly used to evaluate students' performance in this subject. The fundamental objective of EMI is to make it easier for students to manage their academics. The EAP course then consists of two sections: General English for Academic Purposes (GEAP) or English for General Academic Purposes (EGAP), and Specific English for Academic Purposes (SEAP) or English for Specific Academic Purposes (ESAP) (Evans & Morrison, 2011; Kucherenko et al., 2015; Guan 2016; Monbec, 2018; Kizilcik & Daloglu, 2018; Johnson & Tweedie, 2021).

English for Computer Science (ECS)

English for Computer Science (ECS) is a method of instruction designed to assist students in mastering English in the computer science field in order to reach the desired goals or skills. The instructional materials utilized might assist students in comprehending the fundamental ideas of English in their daily lives or as part of their academic program. English is the predominant language used for design and command in computer science, particularly programming. It indicates that English is not just utilized as a language of speech, but also for being able to employ the terms and syntax necessary for issuing computer commands.

ECS was classified as ESP by Belinda (2015), Chaplier (2016), and Septiana et al. (2020). Nonetheless, Yürekli (2016), Benchenane, (2018) Irshad & Anwar (2018) categorized it as English for Academic Purposes (EAP), as EAP is commonly believed to be a subset of ESP. Therefore, it is more specific in an academic setting, particularly when it is a course offered to Computer Science majors.

Wahyuni et al., (2022) describe the position of ECS in ELT as follows:

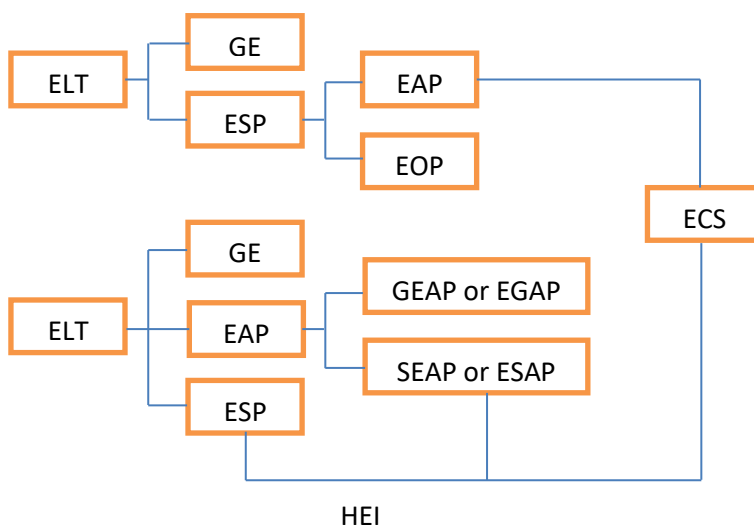

ECS Position in ELT Perspectives

By referring to Hutchinson and Waters (1987), the writers divide ESP into English for Science and Technology Business and Economics, and Social Science. Therefore, the writers consider ECS part of English for Science and Technology. In this context, the writers will only address ECS as ESP in the EFL context taught at HEI as a General Subject in the Computer Science Program. Although the writers categorize ECS as an ESP, it is not possible to comply with common ESP courses normally designed for GE intermediate or advanced students (Dudley-Evans, 1997; Anthony, 1997; Belcher, 2009; Dudley-Evans et al., 1998; Rahman, 2015). The student's level of proficiency is far below the determined competence standard. They are at the fundamental and false beginner levels (Wahyuni et al., 2021).

According to the above, the ECS position in this research is unique in that it is a part of ESP; nonetheless, its demand for attendance defies ESP's theory by allowing students to participate regardless of their level of competence. As a result, an alternative to assisting students in catching up with ECS materials is required.

Content and Language Integrated Learning (CLIL)

Content and Language Integrated Learning (CLIL) is defined as a method of learning based on the mastery of a subject area through the use of a foreign

language and the subject via the use of a foreign language. This phrase is used to describe scenarios in which all academic disciplines or portions of topics are taught in a foreign language to master the subject and acquire the foreign language (Coyle et al., 2010; Ivanova & Zarovniaeva, 2020).

CLIL may occur at any educational level, including preschool, elementary, middle school, secondary school, and higher education. In terms of its position in the curriculum, it might refer to teaching one or more topics in the L2 language or teaching just content-based themes in language programs. Massler et al. (2014) distinguish two forms of CLIL: type A CLIL in topic instruction and type B CLIL in language instruction. Type A, which incorporates immersion, occurs when the learning objectives are centered on the substance of the academic topic taught in a foreign language and the evaluation is mostly content-based. Type B are programs in which foreign language training is thematic and information from other courses, are included in the language session. The objectives and evaluation in this situation are language-related. One example of certain programs in which CLIL is confined to the foreign language classroom and curricular subjects and projects are ECS. Last, type C, is defined as a complete integration of content and language shown in a separate topic but is considered an uncommon occurrence.

Education for Sustainable Development (ESD)

Education has evolved over the years, decades, centuries, and millennia in response to new information, changing conditions, and shifting societal priorities. Educational institutions are responsible for imparting knowledge about the world to equip their students with the values and abilities needed to succeed in the real world, and the flexibility to adapt to the world as it is at any given moment. There has never been a time when humanity needed to solve the environmental catastrophe more than today. Incorporating sustainability into the curriculum will help students see that they, too, have the power to shape and contribute to a more sustainable future. They will feel more assured in their abilities to immediately begin making an impact with the new procedures.

Sustainable development is a hotly debated topic in many spheres, including society at large, the arts, science, technology, the economy, and government (K. E. Portney, 2015; Thiele, 2016; Scoones et al., 2020). Sustainability relies on the 3Ps, Planet, People, and Profits, which stand for the environment, society, and

economics. A fresh take on sustainability developed in the '90s. In this context, sustainability is not seen as a struggle between human ambitions for enhanced well-being and environmental restrictions, but rather as a comprehensive approach to these aspirations that consider environmental considerations.

Taking this stance, environmental, economic, and social sustainability are essential to sustainable development. This concept is oversimplified because it assumes that all three dimensions are equal and that the goal should be to strike a balance between them. The environmental dimension constrains both the social and economic dimensions and the social dimension covers economic dimensions. None of the three supports can hold up independently in the long run. The term 'sustainability' and its definition are continually evolving and adapting in response to the rapid growth of research and the evolution of public opinion (Roobeek et al., 2018; Kawano, 2020).

Education for Sustainable Development (ESD) promotes environmental integrity, economic viability, and social justice by equipping students with the knowledge, skills, values, and attitudes necessary to take action in the real world. It is accomplished through a focus on the UNESCO Framework. ESD is an essential skill for a successful education. It aids mental, interpersonal, emotional, and behavioral education. It is all-encompassing and transformative since it includes the learning content and outcomes, the pedagogy, and the physical learning environment. Its work in bringing about social change has earned it widespread recognition as an important enabler of the Sustainable Development Goals.

The ESD approach values cultural diversity while empowering people of all ages, genders, and generations. Education for Sustainable Development (ESD) should be viewed as an ongoing process throughout one's life.

Instructional Materials

Educators utilize instructional materials to provide educational lessons that incorporate active learning and evaluation. In general, all teaching aids are considered instructional material. In this section, the writers restrict the discussion of instructional materials to modules and e-module.

Module

Russell (1974) defines a module as a collection of instructional materials designed to cover a single conceptual unit of information. The purpose of modules is to assist students in achieving specific, measurable objectives. Instruction can be tailored to meet the needs of each student by using modules. The student may study the topic at their own pace and convenience. Meanwhile, Aguirre Jr (2015) asserted that each learner can advance at his or her own pace when using modules as educational content because modules are sensitive to the principles of individual differences. Modules are now widely recognized as an effective educational method. It is a self-sufficient, independent unit of instruction whose primary focus is the attainment of a few well-defined objectives. The content of a module consists of the resources and instructions required to accomplish these objectives.

A module as a thorough, adjustable standalone unit is a strict instructional concept for a student, a teacher, learning resources, and instructional innovations. A learning set that focuses on learning materials and activities for students and a structural and systematic element within the educational discipline framework. The training organization follows the modular organizing idea of study material with professionally-oriented modules. A high-integrity educational and technology module includes educational and technical material that provides a database of material, an action plan, and methodological guidance for achieving study objectives. It is a training program adapted to the learner's needs in how they learn, what they learn, how independent they are, and how rapidly they learn and use their minds (Kolegova & Levina, 2022).

The structure and design of a module might change based on its purpose and the institution where it is prepared. The alternative module components will be; 1) Title, 2) About the Module, 3) Starting Out, 4) Point of Language, 5) Practice, and 6) Assessment. The Web-Based Interactive Module for ESD in ECS will have a more varied structure than the standard accessible learning modules. It uses diverse strategies better suited to ECS students who are English Language Learners.

E-Module

An electronic module (e-module) is a collection of non-printed digital learning materials that are organized systematically and may be utilized freely by students to solve issues in their unique manner. The benefits of e-modules include their

practical, long-lasting, and cost-effective manufacturing over standard print modules (Fausih & Danang, 2015).

Today's students are more at ease with modern technology, which increases their motivation and academic achievement. The usage of information communication technology in various fields of higher education has increased. The e-module is a cutting-edge use of information and communication technology that aims to increase student engagement and learning results (Triyono, 2021).

The millennial generation is inextricably linked to digital education. As a result, using technology to enhance learning is critical for achieving a higher learning outcome (Fatdha & Wahyuni, 2017). Learning progressive material may aid in the process of education. Science and technology are advancing at a breakneck pace these days. Additionally, there is a higher emphasis on education in the growth. The usage of interactive instructional media must be studied and adapted to the current state of development to forge form to function smoothly. Interactive media delivers recorded educational resources (visual, audio, and video) in a computer-controlled environment. Interactive multimedia provides for direct connection between students and their surroundings, as well as self-study tailored to the talents and interests of the students (Yulando et al., 2019).

Suarsana and Mahayukti (2013) state that e-modules are available in several different forms and sizes. It is interactive and simplifies navigation. An e-module is also capable of displaying pictures, audio, and video animation, as well as being outfitted with assessments or quizzes that serve as a means of establishing reciprocity naturally occurring impacts, which is the distinguishing feature of the benefit of interactive e-module. There are several benefits of establishing an e-module, 1) studying at a time and place that works for students, 2) accessible online and offline, 3) provided with interactive features, 4) saving printing costs, 5) offering updated content, 6) interactive assessment, 7) combining education and entertainment, 8) equipping students with the unavailable classroom learning environment, 9) encouraging students to be freely expressed themselves 10) enabling students to develop their deep learning (Trilestari & Almunawaroh, 2020).

A web-based interactive module for ESD in ECS is proposed in this case. It is intended to help students overcome their limited classroom time; by allowing them to learn outside of class at their own pace and convenience and to maintain their

interest in learning. The implementation of digital technology is believed to improve students' learning ability and positively affect their learning achievement. Each module is laid out in five essential components; Starting Out, Points of Language, Practice, Assessment, and Expansion. By eliminating the need for printed materials, and using the internet students of all backgrounds will be able to benefit from an education that is both equitable and environmentally friendly.

Related Research

There have been several studies dealing with instructional materials for ECS and ESD. Amna (2020) in her research intends to determine the need for an English module and a learning method for computer science students. To characterize the students' demands, she employed a descriptive-analytic and qualitative methodology by using interviews and questionnaires to obtain data. Four teachers and 150 students were selected by purposeful random selection. This research revealed the critical need for an English module for students. It should include additional grammar and speaking skills, as well as group work and activities outside of class.

Then, Septiana et al., (2020) carried out a need analysis in a computer science program. Its purpose was to provide a suitable English curriculum for computer science students there. What students need is determined via the use of Target Situation Analysis (TSA), Deficiency Analysis (DA), and Strategy Analysis in this research (SA). The descriptive-analytical approach is used with 61 students, lecturers, and the institute's director. Data was gathered using various methods, including surveys, interviews, observation, and document examination. The findings indicate that the target requirements are communication and writing skills. The two fundamental language abilities are given significant attention in developing the English curriculum. Additionally, ECS needs a learning approach that emphasizes practice more than theory. Incorporating technology into the learning process is necessary to make classroom activities more exciting. The investigation comes to an end with the creation of a curriculum that should be used.

Symonenko (2020) did a content analysis of current English language course materials and nine ECS textbooks to determine the content of foreign language instruction. Aspects that have been emphasized in her research include content that is oriented toward professional development, the presence of exercises and tasks, job-related situations, and activities that help students improve their overall

language proficiency, as well as the availability of additional materials, applications, and self-study resources. It is claimed that English language teaching aids in information technology, computer engineering, computing, and software engineering can be used in the learning process. However, their application must be thoroughly refined and modified before they can be used successfully. ECS in the 21st century should involve a significant intensification of language training through a set of active professional and linguistic training measures within separate practical courses. Foreign language training should take place in a real-life flexible, variable context, considering the field of knowledge and its current state, as well as sustainable development strategies. Foreign language teachers must alter the content, formats, and methods of ESD foreign language instruction to fulfill professional community requirements and ensure students have a sufficient command of English at the right level.

Lei & Allen (2022) did a scoping review to find 54 relevant articles on computer science education for English language learners who are learning computer science in English and to track the similarities among these papers. They then conducted a qualitative analysis to find meta-themes and sub-themes in the data. Meta-themes include looking into what is good or bad for ECS students, focusing on language skills that can be used together, and looking at pedagogical and curriculum methods, among other things. English learners studying computer science in English have received more attention. The topics help and hinder English Language Learners (ELLs), integrative language abilities, and pedagogical and curricular strategies. Future research could focus on culturally relevant courses and translanguaging. Both paths focus on students' knowledge, cultural backgrounds, and life experiences.

Meanwhile, Koniukhov & Osadcha (2020) did their research in a computer science program and stated that software development using an object-oriented approach is a significant area of professional work for software engineers. Graduates of higher education institutions should understand its fundamental principles. They are expected to use object-oriented programming languages, apply them to exist and make their own decisions, decompose and compose tasks, and document the process of building an object model, among other skills. In certain circumstances, the developers' lack of basic competencies contributes to the poor quality of software products, which endangers future sustainability.

Other risks include a narrow emphasis on immediate duties and objectives, a lack of awareness of global economic, environmental, and social challenges, possibilities for the present and future, and a lack of accountability to future generations. As a result, it is necessary to provide circumstances in higher education institutions for students to acquire the required professional competencies to overcome or mitigate the effects of IT products at the level of individual IT professionals or organizations.

Climate change, environmental degradation, biodiversity loss, poverty, and inequality are some of the most pressing issues facing the globe today. There are four ways that computer scientists may contribute to this objective. One is reducing the immediate negative effects of computers, such as their power consumption and the economic and societal expenses involved in making, maintaining, and disposing of their parts. Computers also directly impact energy efficiency and scientific research because they can change systems and the way people think (Mankoff et al., 2008).

The research conducted by Koniukhov & Osadcha (2020) strengthens the previous one conducted by Gordon (2010), who surveyed 140 Computer Science students' views on sustainable development topics. The results show that a total of 27 percent of those who answered the survey did so. The generation in question was mostly male (80%) and under the age of 29 (65% were under the age of 20, and 24% were 20 - 29). The phrase "sustainable development" was familiar to 55% of those who answered the survey questions.

A qualitative approach was used in examining the relevance of ICT-driven Computer Science Education in sustainable development (Nwankwo & Njoku, 2020). The writers argue for the proper integration of ICT-based pedagogy into the existing curriculum in tertiary institutions to provide a better learning experience and high-quality education delivery for development. The different areas in which computer science and information and communications technology (ICT) are employed for sustainable development are suitably examined. They also reviewed the difficulties and roadblocks that have arisen in the implementation of information and communication technology (ICT) solutions to achieve the Sustainable Progress Goals (SDG) in higher education and technological development. There needs to be a paradigm shift to an integrated education model in Nigeria, which looks at how information and communication technology (ICT) is

used in all academic processes at all three levels of education. This way, Nigeria can help meet the Sustainable Development Goals.

The Web-Based Interactive Module for ESD in ECS

The module in the form of a Website for English Computer Science by integrating ESD will be more engaging for students for the following reasons:

1. Computer Science students deal with computers most of the time so that it will be in line with their online activities and habits.
2. The students are also digital natives who were born and live in the digital era where accessing the website is part of their daily activities.
3. The availability of internet access will also support the usage of the module.
4. Integrating ESD into ECS will attract students to learn as they are involved in real-life and have perspectives on global issues as they are part of the global citizen.
5. The interactive module enables students to learn at their capacity and convenient time but they will still be able to interact with classmates and their teacher.
6. The combination of various kinds of audio-visual materials will retain student engagement in learning.

CONCLUSION

The ECS position is unique in that it is part of ESP; however, its attendance requirement contradicts the theory of ESP by permitting students to participate regardless of their level of competence. As a complete integration of content and language that is shown in a separate topic, an alternative method of assisting students in catching up on ECS materials is required.

While ESD is essential to recent education, there is no evidence that ESD has been incorporated into ECS, although ESD has begun to participate in computer science programs. ESD equips students with the necessary knowledge, skills, values, and attitudes to make informed decisions and engage in responsible behavior that promotes environmental integrity, economic viability, and social justice. It is a crucial lifelong practice for quality education and facilitates learning on cognitive, social, emotional, and behavioral learning. Comprehensive and transformative, it includes learning content and outcomes, pedagogy, and the physical learning environment. It is recognized as a key facilitator of Sustainable

Development Goals and fulfills its mission via social transformation. Respecting cultural differences, ESD empowers individuals of all genders, ages, and generations. Quality education must incorporate Sustainable Development as a lifelong process.

To make learning more engaging, the writers propose to build a web-based interactive module for ESD in ECS. The module is expected to permit students to study at their own pace and based on their abilities. This module will contribute to the SDGs through its paperless nature and assist ECS students in overcoming the limitations of classroom time and relating what they learn to future issues, careers, and professionalism.

REFERENCES

- Adawiyah, R., & Susilawati, L. A. (2020). Implementation of an Interactive E-Module to Improve Concept Understanding of Students. *Advances in Social Science, Education and Humanities Research*, 513, 78–84.
- Aguirre Jr, D. (2015). Instructional materials development manual. *Available at SSRN 2703250*.
- Amna, S. (2020). Need Analysis of Developing English Module Through Poster Presentation Assisted by Vlog. *Eighth International Conference on Languages and Arts (ICLA-2019)*, 43–47.
- Amna, S., & Christina, D. (2021). A Need Analysis for English Speaking and Listening Assessment Media with Web Responsive in Computer Science Faculty. *JURNAL ARBITRER*, 8(2), 148–156.
- Andas, N. H., Karman, K., & Mulyadi, M. (2021). A Need Analysis of Learning English for Computer Science Students. *The Journal of English Literacy Education: The Teaching and Learning of English as a Foreign Language*, 8(2), 68–83.
- Anthony, L. (1997). Defining English for specific purposes and the role of the ESP practitioner. *Center for Language Research 1997 Annual Review*, 115–120.
- Belcher, D. (2009). What ESP is and can be: An introduction. *English for Specific Purposes in Theory and Practice*, 1–20.

- Benchenane, D. (2018). *Implementing an ESP Course to Computer Sciences Students: Case Study of Master's Students at the University of Mustapha Stambouli Mascara*. Université de Tlemcen-Abou Bekr Belkaid.
- Brateanu, A., Strang, T. M., Garber, A., Mani, S., Spencer, A., Spevak, B., Thomascik, J., Mehta, N., & Colbert, C. Y. (2019). Using an adaptive, self-directed web-based learning module to enhance residents' medical knowledge prior to a new clinical rotation. *Medical Science Educator*, 29(3), 779–786.
- Castellanos, P. M. A., & Queiruga-Dios, A. (2021). From environmental education to education for sustainable development in higher education: a systematic review. *International Journal of Sustainability in Higher Education*.
- Chaleta, E., Saraiva, M., Leal, F., Fialho, I., & Borralho, A. (2021). Higher Education and Sustainable Development Goals (SDG)—Potential Contribution of the Undergraduate Courses of the School of Social Sciences of the University of Évora. *Sustainability*, 13(4), 1828.
- Coyle, D., Hood, P., & Marsh, D. (2010). *Content and Language Integrated Learning*. Cambridge University Press.
- Dudley-Evans, T. (1997). Five questions for LSP teacher training. *Teacher Education for LSP*, 58–67.
- Dudley-Evans, T. (1998). *An Overview of ESP in the 1990s*.
- Dudley-Evans, T., St John, M. J., & saint John, M. J. (1998). *Developments in English for specific purposes: A multi-disciplinary approach*. Cambridge university press.
- Erna, M., & Anwar, L. (2021). Interactive E-Module Using Zoom Cloud Meeting Platform to Reduce Misconceptions on Salt Hydrolysis Material. *Journal of Education and Learning (EduLearn)*, 15(2), 283–290.
- Evans, S., & Morrison, B. (2011). The first term at university: Implications for EAP. *ELT Journal*, 65(4), 387–397.
- Fatdha, T. S., & Wahyuni, D. S. (2017). Designing English Learning Media for Starter Learners at Elementary Schools based on Interactive Multimedia.

International Conference of Applied Science on Engineering, Business, Linguistics and Information Technology, 204–209.

- Fausih, M., & Danang, T. (2015). Pengembangan Media E-Modul Mata Pelajaran Produktif Pokok Bahasan. *Instalasi Jaringan Lan (Local Area Network)’ Untuk Siswa Kelas Xi Jurusan Teknik Komputer Jaringan Di Smk Nengeri*, 1.
- Floris, F. D. (2008). Developing English for general academic purposes (EGAP) course in an Indonesian university. *K@ Ta*, 10(1), 53–62.
- Franco, I., Saito, O., Vaughter, P., Whereat, J., Kanie, N., & Takemoto, K. (2019). Higher education for sustainable development: actioning the global goals in policy, curriculum and practice. *Sustainability Science*, 14(6), 1621–1642.
- Gordon, N. (2010). Education for sustainable development in Computer Science. *Innovation in Teaching and Learning in Information and Computer Sciences*, 9(2), 1–6.
- Grosbeck, G., Țîru, L. G., & Bran, R. A. (2019). Education for sustainable development: Evolution and perspectives: A bibliometric review of research, 1992–2018. *Sustainability*, 11(21), 6136.
- Guan, X. F. (2016). Probe into the Differences between EAP, ESP and EOP Teaching in College English Teaching. *Proceedings of the 2016 International Conference on Education, E-Learning and Management Technology*, 44, 543–547.
- Hiran, K. K., Khazanchi, D., Vyas, A. K., & Padmanaban, S. (2021). *Machine Learning for Sustainable Development* (Vol. 9). Walter de Gruyter GmbH & Co KG.
- How, M.-L., Cheah, S.-M., Chan, Y.-J., Khor, A. C., & Say, E. M. P. (2020). Artificial intelligence-enhanced decision support for informing global sustainable development: A human-centric Ai-Thinking approach. *Information*, 11(1), 39.
- Howlett, C., Ferreira, J.-A., & Blomfield, J. (2016). Teaching sustainable development in higher education: Building critical, reflective thinkers through an interdisciplinary approach. *International Journal of Sustainability in Higher Education*.
- Hromkovič, J., Kohn, T., Komm, D., & Serafini, G. (2016). Combining the power of python with the simplicity of logo for a sustainable computer science

- education. *International Conference on Informatics in Schools: Situation, Evolution, and Perspectives*, 155–166.
- Hutchinson, T., & Waters, A. (1987). *English for specific purposes*. Cambridge university press.
- Irshad, I., & Anwar, B. (2018). English for Specific Purposes: Designing an EAP Course for Computer Science Students. *Journal of Education and Educational Development*, 5(1), 156–171.
- Ivanova, R. P., & Zarovniaeva, S. S. (2020). Application of CLIL Technology for the Bachelor's Program "Pedagogics with Two Majors: Foreign Language (English) and Computer Science." *ARPHA Proceedings*, 3, 903.
- Kaneko, E., Rozycki, W., & Orr, T. (2009). Survey of workplace English needs among computer science graduates. *2009 IEEE International Professional Communication Conference*, 1–6.
- Kawano, E. (2020). Solidarity economy: Building an economy for people and planet. In *The New Systems Reader* (pp. 285–302). Routledge.
- Kolegova, I. A., & Levina, I. A. (2022). The Impact of Modular Learning of English for Specific Purposes on Students' Satisfaction of Education Process. *Вестник Южно-Уральского Государственного Университета. Серия: Образование. Педагогические Науки*, 14(1), 31–39.
- Koniukhov, S., & Osadcha, K. (2020). *Implementation of education for sustainable development principles in the training of future software engineers*.
- Kuhlman, T., & Farrington, J. (2010). What is sustainability? *Sustainability*, 2(11), 3436–3448.
- Lässig, J. (2016). Sustainable development and computing—An introduction. In *Computational Sustainability* (pp. 1–12). Springer.
- Lavrysh, Y., & Lytovchenko, I. (2019). The case of education for sustainable development approaches implementation at English language classes at the technical university in Ukraine. *Pedagogy*, 91(5), 736–749.
- Leal Filho, W., Brandli, L., Castro, P., & Newman, J. (2017). *Handbook of theory and practice of sustainable development in higher education* (Vol. 1). Springer.

- Lei, Y., & Allen, M. (2022). English Language Learners in Computer Science Education: A Scoping Review. *Proceedings of the 53rd ACM Technical Symposium on Computer Science Education V. 1*, 57–63.
- Lestariningsih, F. E., Susyeta, A., & Krisnawati, L. D. (2017). Developing English Instructional Materials for Students of Computer Science Department (A Needs Analysis). *UAD TEFL International Conference*, 1, 261–269.
- LKPP-Unhas. (2015). *Format Bahan Ajar, Buku Ajar, Modul dan Panduan Praktik*. LKPP Unhas.
- Lozano, R., Merrill, M. Y., Sammalisto, K., Ceulemans, K., & Lozano, F. J. (2017). Connecting competences and pedagogical approaches for sustainable development in higher education: A literature review and framework proposal. *Sustainability*, 9(10), 1889.
- Mahmood, R. A. (2017). *Needs Analysis in ESP for Computer Science Students at the University of Human Development*. Eastern Mediterranean University (EMU)-Doğu Akdeniz Üniversitesi (DAÜ).
- Maley, A., & Peachey, N. (2017). Integrating global issues in the creative English language classroom: With reference to the United Nations Sustainable Development Goals. *London: British Council*, 208.
- Mankoff, J., Kravets, R., & Blevis, E. (2008). Some computer science issues in creating a sustainable world. *Computer*, 41(8), 102–105.
- Massler, U., Stotz, D., & Queisser, C. (2014). Assessment instruments for primary CLIL: The conceptualisation and evaluation of test tasks. *The Language Learning Journal*, 42(2), 137–150.
- Mateusz, P., Danuta, M., Małgorzata, Ł., Mariusz, B., & Kesra, N. (2018). TOPSIS and VIKOR methods in study of sustainable development in the EU countries. *Procedia Computer Science*, 126, 1683–1692.
- Mohammadnia, Z., & Moghadam, F. D. (2019). Textbooks as resources for education for sustainable development: A content analysis. *Journal of Teacher Education for Sustainability*, 21(1), 103–114.

- Monbec, L. (2018). Designing an EAP curriculum for transfer: A focus on knowledge. *Journal of Academic Language and Learning*, 12(2), A88–A101.
- Mulyadi, M., Atmazaki, A., & Syahrul, R. (2019). The Development of Interactive Multimedia E-Module on Indonesia Language Course. *1st International Conference on Innovation in Education (ICoIE 2018)*, 291–295.
- Nisar, S. (2016). The present English language needs of computer science undergraduates: Case study in International Islamic University, Islamabad. Department of English. *International Islamic University, Islamabad*.
- Nwankwo, W., & Njoku, C. (2020). Sustainable development in developing societies: the place of ICT-driven computer education. *International Journal of Emerging Technologies in Learning (IJET)*, 15(12), 290–297.
- Prasetya, A. (2021). Electronic Module Development with Project Based Learning in Web Programming Courses. *International Journal of Computer and Information System (IJCIS)*, 2(3), 69–72.
- Puspitasari, I. (2013). English For Computer Science: Sebuah Analisis Kebutuhan Bahasa Inggris Pada Mahasiswa Teknik Informatika. *Probisnis*, 6(1).
- Rahdiyanta, D. (2016). Teknik penyusunan modul. *Artikel.(Online) Http://Staff.Uny.Ac.Id/Sites/Default/Files/Penelitian/Dr-Dwi-Rahdiyanta-Mpd/20-Teknik-Penyusunan-Modul.Pdf*. Diakses, 10.
- Rahman, M. (2015). English for Specific Purposes (ESP): A Holistic Review. *Universal Journal of Educational Research*, 3(1), 24–31.
- Rahmatsyah, S., & Dwiningsih, K. (2021). Development of interactive E-Module on the periodic system materials as an online learning media. *Jurnal Penelitian Pendidikan IPA*, 7(2), 255–261.
- Ramadhan, S., & Linda, R. (2020). Pengembangan E-Module Interaktif Chemistry Magazine Berbasis Kvisoft Flipbook Maker Pada Materi Laju Reaksi. *Jurnal Zarah*, 8(1), 7–13.
- Rashid, L. (2019). Entrepreneurship education and sustainable development goals: A literature review and a closer look at fragile states and technology-enabled approaches. *Sustainability*, 11(19), 5343.

- Roobeek, A., de Swart, J., & van der Plas, M. (2018). *Responsible Business: Making Strategic Decisions to Benefit People, the Planet and Profits*. Kogan Page Publishers.
- Russell, J. D. (1974). *Modular Instruction: A Guide to the Design, Selection, Utilization and Evaluation of Modular Materials*.
- Scoones, I., Stirling, A., Abrol, D., Atela, J., Charli-Joseph, L., Eakin, H., Ely, A., Olsson, P., Pereira, L., & Priya, R. (2020). Transformations to sustainability: combining structural, systemic and enabling approaches. *Current Opinion in Environmental Sustainability*, 42, 65–75.
- Septiana, I., Petrus, I., & Inderawati, R. (2020). Needs analysis-based English syllabus for computer science students of Bina Darma University. *English Review: Journal of English Education*, 8(2), 299–310.
- Suarsana, I. M., & Mahayukti, G. A. (2013). Development of e-module oriented solving problems to improve skills thinking critical student. *Indonesian Education Journal*, 2(2), 266.
- Sund, P., & Gericke, N. (2020). Teaching contributions from secondary school subject areas to education for sustainable development—a comparative study of science, social science and language teachers. *Environmental Education Research*, 26(6), 772–794.
- Suppan, L., Abbas, M., Stuby, L., Cottet, P., Larribau, R., Golay, E., Iten, A., Harbarth, S., Gartner, B., & Suppan, M. (2020). Effect of an e-learning module on personal protective equipment proficiency among prehospital personnel: web-based randomized controlled trial. *Journal of Medical Internet Research*, 22(8), e21265.
- Suryawanshi, K., & Narkhede, S. (2015). Green ICT for sustainable development: A higher education perspective. *Procedia Computer Science*, 70, 701–707.
- Syakur, A., & Sabat, Y. (2020). The Effectiveness of Coopertative Learning (STAD and PBL type) on E-learning Sustainable Development in Higher Education. *Journal of Development Research*, 4(1), 53–61.
- Symonenko, S. (2020). *Complementing content of English courses for enhancing communication of IT-professionals for sustainable development*.

- Trilestari, K., & Almunawaroh, N. F. (2020). E-Module as a Solution for Young Learners to Study at Home. *Proceedings of the 4th Sriwijaya University Learning and Education International Conference (SULE-IC 2020)*, 364–369.
- Triyono, S. (2021). *Dinamika penyusunan e-modul*. Penerbit Adab.
- Verhulst, E., & Lambrechts, W. (2015). Fostering the incorporation of sustainable development in higher education. Lessons learned from a change management perspective. *Journal of Cleaner Production*, 106, 189–204.
- Wahyuni, D. S., Darmansyah, D., & J. Yeni, F. (2021). Writing skills deficiency in English for specific purposes (Esp): English for computer science. *Journal of Applied Studies in Language*, 5(1), 95–100.
- Wahyuni, D. S., Rozimela, Y., Ardi, H., Mukhaiyar, M., & Darmansyah, D. (2022). PROSPER (Project, Sustainability, and Perseverance) Learning Model in English for Computer Science. *Sustainability*, 14(24), 16749.
- Yulando, S., Sutopo, S., & Franklin Chi, T. (2019). Electronic Module Design and Development: An Interactive Learning. *American Journal of Educational Research*, 7(10), 694–698.
- Zygmunt, T. (2016). Language education for sustainable development. *Discourse and Communication for Sustainable Education*, 7(1), 112.